

Wilderness Equipment



i-SHADOW

Transverse-ridge tent design is something we nailed over 35 years ago. The many imitations of this 4-season, single-pole WE original still don't compare. The i-Shadow's long history, recent consultative development to meet the specific requirements of today's outdoor educators and our insistence on the highest quality materials and fittings are the reasons for this. This simple, single-pole tent is easy to erect, has space for up to 3 persons and a large vestibule for gear. The heavy-duty zips, original easy-maintenance features and superior fabric coatings set this tent up for the longest possible service life.

SPECIFICATIONS

- » Single, transverse pole, 4-season, 2/3 person tent
- » Integral pitch - pole in outer, inner attaches under, outer can be used alone
- » Min Wt 2.85 kg
- » Packed Wt 3.15 kg
- » Floor Dimensions: 2.1m x 1.7m widest
- » Outer Tent Fabric: 75d ripstop polyester, dwr face, tape-sealed, 3000mm PE back coating
- » Outer Tent Colour: Sky Blue
- » Inner Tent: Light Grey 40d air-permeable ripstop nylon, Black 40d nylon mesh door screens.
- » Floor: Deep, unstressed tub, 100d nylon with 8,000mm HH PE coating
- » Poles: 1 x 7071-T6 HT aluminium, 10.2mm, insert-tube type.
- » Pegs: 8 x Hooked top HT Aluminium pin type.

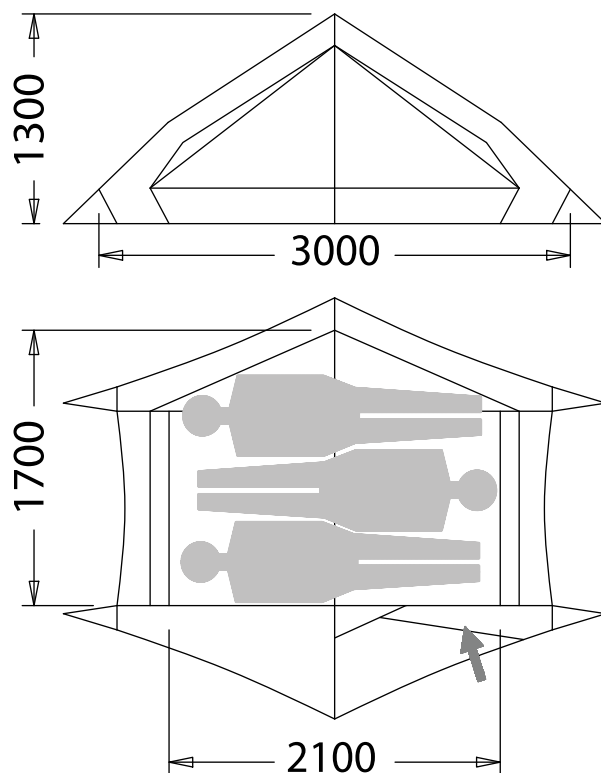

Hexagonal ground sheet optional accessory

